



HMK04/24

Max Flow: 35 gpm (133 lpm) / 60 gpm (227 lpm)



HMK04/24 DURAMAX® Spin-On Filters

Working Pressures to: 500 psi
3450 kPa
35 bar

Rated Static Burst to: 1000 psi
6895 kPa
69 bar

Flow Range To:	HMK04	HMK24
	35 gpm 133 lpm	60 gpm 227 lpm



Parallel Flow

Features

HMK04 (single) and HMK24 (double) Duramax® spin-on filters feature a die-cast aluminum head, heavy-duty steel body, and die-cast aluminum top plate for added strength. A special head-to-canister O-Ring seal prevents leakage. Buna-N seals are standard; Viton® seals are available on some models.

Both models use the same replacement filters and feature identical pressure ratings, but the HMK24 handles greater flow capacity. There's no need to inventory two different replacement filters. A full range of media options are available, using Donaldson's exclusive Synteq™ synthetic media. Choose the indicator types and bypass options to suit your application.

Beta Rating

- Performance to $\beta_{<4(c)} = 1000$

Porting Size Options

- HMK04 ¾", 1" NPT
- HMK04 SAE-12, SAE-16 O-ring
- HMK24 SAE-20, O-ring
- HMK24 1¼" SAE 4-Bolt Flange Code 61

Replacement Filter Lengths

- 5.97" / 152mm
- 9.4" / 240mm

Standard Bypass Ratings

- 25 psi / 173 kPa / 1.73 bar
- 50 psi / 345 kPa / 3.5 bar
- No Bypass

Assembly Weight

- HMK04 with short filter: 3.9 lbs/1.8 kg
- HMK04 with long filter: 4.8 lbs/2.2 kg
- HMK24: with short filter: 7.8 lbs/3.5 kg
- HMK24: with long filter: 9.6 lbs/4.4 kg

Operating Temperatures

- -20°F to 250°F / -29°C to 121°C (synthetic)
- -20°F to 225°F / -29°C to 107°C (cellulose)

Housing Fatigue Strength Ratings*

- 100,000 Cycles: 0-500 psi / 0-3450 kPa / 34.5 bar
- 300,000 Cycles: 0-400 psi / 0-2758 kPa / 27.6 bar
- 1,000,000 Cycles: 0-350 psi / 0-2415 kPa / 24 bar

Filter Collapse Ratings

- 150 psid / 10 bar
- 300 psid / 20 bar also available

HMK04/24 Specification Illustrations

All dimensions are shown in inches [millimeters].

Assembly - Side Views

Long Assembly

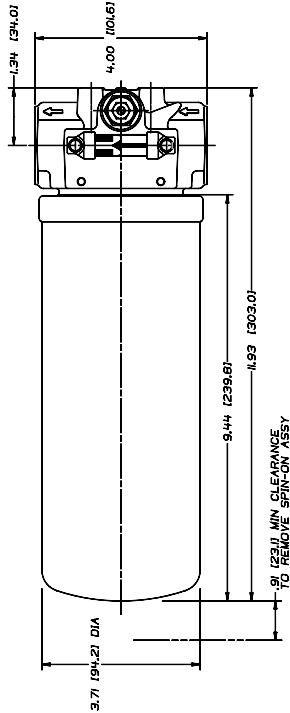

Short Assembly

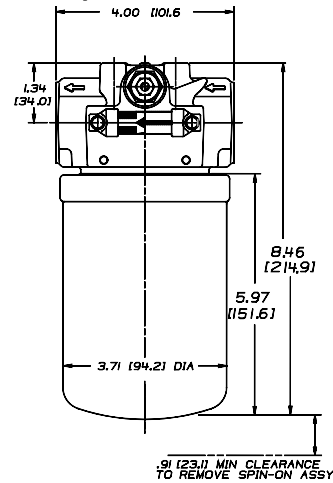

Head - Top & Side Views

HMK04 Head Top View with DC Electrical Indicator

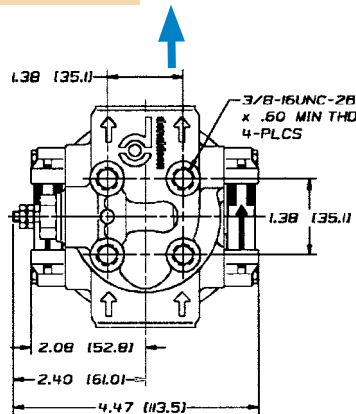

HMK04 Head Top View with AC/DC Electrical Indicator

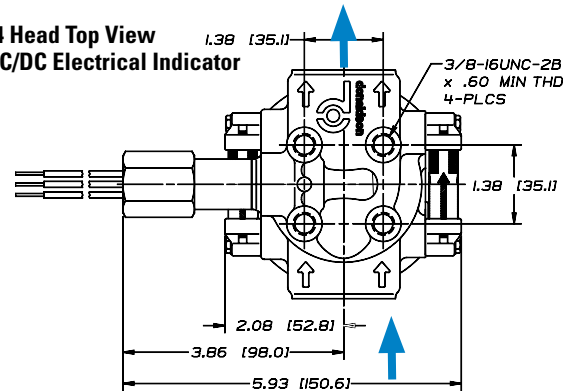

HMK24 Head Side View

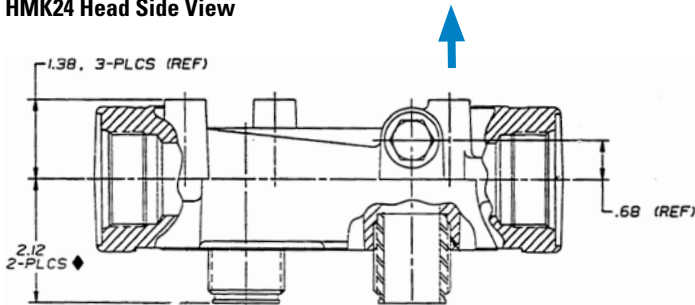

HMK24 Head Top View

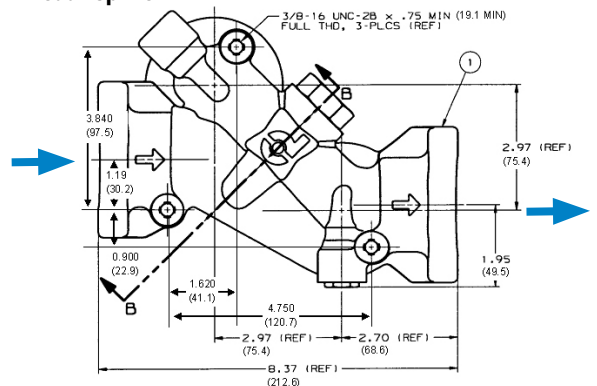

Applications

- Case Drains
- Cooling Circuits
- Fluid Conditioning Systems
- Fuel Transfer
- Hydrostatic Charge Pumps
- Lube Oil Systems
- Power Transmissions
- Return Lines
- Side Loop Systems



HMK04/24

Max Flow: 35 gpm (133 lpm) / 60 gpm (227 lpm)



HMK04/24 Components

Filter Choices

Media Type	$\beta_{x(c)} = 2$ Rating based on ISO 16889	$\beta_{x(c)} = 1000$	Length		Donaldson Part No.	Comments
			in	mm		
Synthetic	Rating based on ISO 16889	<4 μm	9.4	240	P165185	¹ Viton® O-ring
		6 μm	5.97	152	P165354	
		6 μm	9.4	240	P165332	
		11 μm	5.97	152	P163542	500 psi collapse
		11 μm	5.97	152	P164375	
		11 μm	9.4	240	P164378	
		13 μm	9.4	240	P164056	¹ Viton O-ring
		14 μm	9.4	240	P177047	
		22 μm	9.4	240	P164059	¹ Viton O-ring
		23 μm	9.4	240	P163567	500 psi collapse
		23 μm	5.97	152	P164381	
		23 μm	9.4	240	P164384	
		50 μm	5.97	152	P165335	
50 μm	9.4	240	P165338			
Water Absorbing	10 μm		9.4	240	P560584	
Wire Mesh	150 μm		9.4	240	P573301	



NOTE:
Lubricate filter-to-head threads when installing new filter to prevent thread damage. Heavyweight gear lube is recommended.

Filter Notes

- Refer to table in the Technical Reference Guide for fluid compatibility with our filter media.
 - Standard filter collapse rating is 150 psi, except as noted.
 - Thread size is 1 3/8"-12 UNF-2B
 - ¹ Filters with seals made of Buna-N® are appropriate for most applications involving petroleum oil. Filters with seals made of Viton® (a fluoropolymer) are required when using diester, phosphate ester fluids, water glycol, water/oil emulsions and HWCF (high water content fluids) over 150°F. Donaldson offers both types.
- Buna-N® Viton® are a registered trademarks of E. I. DuPont de Nemours and Company.

Head Choices for HMK24 (double)



Port Size	Bypass Rating	Indicator Options ¹	Part No.
SAE-20 O-Ring	None	A, B, C, E, F, H	P179609
1 1/4" SAE 4-Bolt Code 61	50 psi	A, B, C, E, F, H	P179582

¹Reference illustration on next page for service indicator styles.

Performance Data

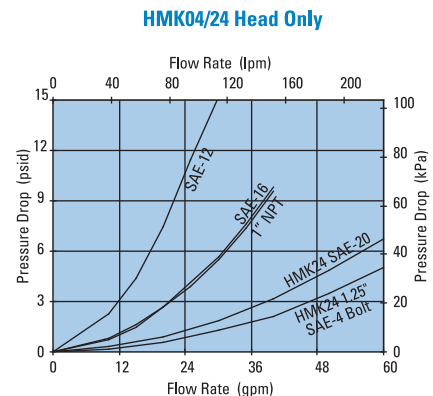
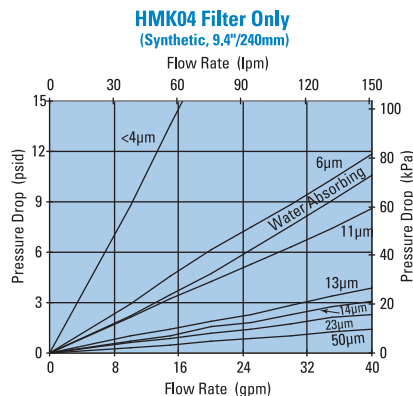
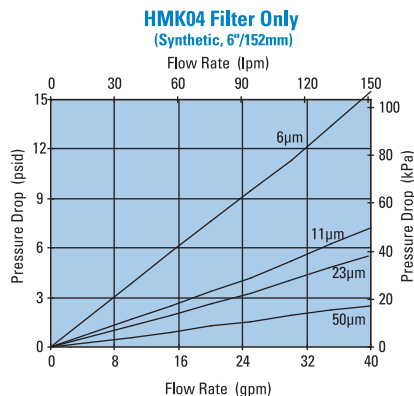

Head Choices for HMK04 (single)

Port Size	Bypass Rating	Standard Indicator Style & Location ^{1,2}	Indicator Options	Head Part No.	
3/4" NPT	25 psi / 172 kPa	None	None	P169317	
		D (Visual), Left Side	None	P169310	
SAE-12 O-Ring	25 psi / 172 kPa	None	None	P167473	
		D (Visual), Left Side	None	P166387	
	No Bypass	D (Visual), Left Side (25 psi)	None	P169320	
		None	None	P165434	
No Bypass	D (Visual), Left Side (50 psi)	None	P173750		
SAE-12 O-Ring (3 ports)	50 psi / 345 kPa	A (Electrical, P165194)	B, C, E, F, H	P167529	
1" NPT	25 psi / 172 kPa	D (Visual), Both Sides	A, B, C, E, F, H	P166086	
		None	None	P169309	
		D (Visual), Left Side	None	P166416	
SAE-16 O-Ring	15 psi / 100 kPa	None	A, B, C, E, F, H	P176569	
SAE-16 O-Ring	25 psi / 172 kPa	None	None	P163681	
		D (Visual), Left Side	None	P166417	
		D (Visual), Both Sides	A, B, C, H	P166088	
		E (Electrical, P177361)	None	P176568	
		A (Electrical, P162400)	B, C, H	P165537	
		No Bypass	D (Visual), Both Sides (25 psi)	A, B, C, F, H	P166664
			A (Electrical, P162400)	B, C, F, H	P166902
		50 psi / 345 kPa	D (Visual, Right Side)	All	P179381
		No Bypass	None	None	P164667
		50 psi / 345 kPa	None	None	P167201
A (Electrical, P165194)	B, C, E, H	P166862			
SAE-16 O-Ring	5 psi	D (Visual), Both Sides	All	P564850	
1" NPT	No Bypass	D (Visual), Left Side (25 psi/D)	None	P564484	
1" NPT	25 psi / 172 kPa	D (Visual), Left Side (25 psi/D)	None	P564485	

NOTE:

Lubricate filter-to-head threads when installing new filter to prevent thread damage. Heavyweight gear lube is recommended.

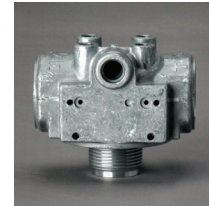

Head Notes

¹Reference illustration below for indicator styles.
²Donaldson uses the inlet port as the reference point. "Left side," for instance, means that the indicator mounts on the side of the filter head that is on your left when you face the inlet port.

3-Port Head for Charge Pumps



The **P167529** head is designed with a 50 psi / 3.45 bar third port bypass valve that diverts all bypass flow back to the reservoir, instead of going straight through the head and into the system as it does in 2-ported heads. Unfiltered fluid is NOT allowed into the system in the case of plugged filters. Designed primarily for charge pump applications.

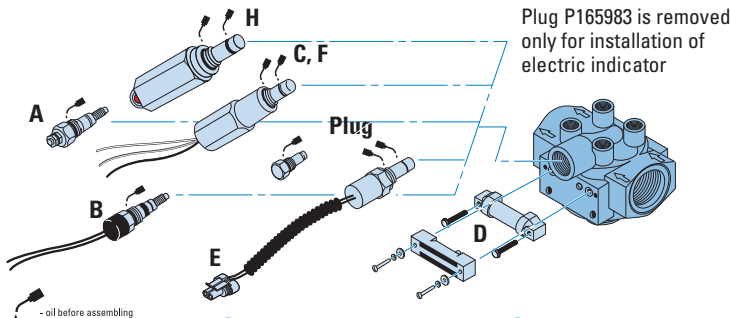

Service Indicator Choices

Use with Bypass Valve Pressure of:	Indicator Part No.	Indicator Style ³
Visual Models (non-electric)²		
15 psi / 103 kPa	P162642	D
25 psi / 172.5 kPa	P162696	D
50 psi / 345 kPa	P167580	D
N/A	P165984	(blank plate)
25 psi / 172.5 kPa	P165965	D Heavy-Duty
50 psi / 345 kPa	P574177	D Heavy-Duty
25 psi / 172.5 kPa	P575334	H Pop up
50 psi / 345 kPa	P575335	H Pop up

Indicator Notes

¹All electric models have a maximum operating temperature of 250°F / 121°C.

²All non-electric models have a maximum operating temperature of 180°F / 82°C.

³Complete details on all service indicators can be found in the accessories section.

Service Indicator Choices

Use with Bypass Valve Pressure of:	Indicator Part No.	Indicator Style ³	Description
Electric Models¹			
5 psi / 34.5 kPa	P163642	A	Single post DC.
15 psi / 103 kPa	P163601	A	Single post DC.
25 psi / 172.5 kPa	P163839	A	Single post DC. N.C.
25 psi / 172.5 kPa	P162400	A	Single post DC. N.O.
25 psi / 172.5 kPa	P171143	B	DC 2-wire.
25 psi / 172.5 kPa	P173944	C	AC/DC 3-wire.
50 psi / 345 kPa	P165194	A	Single post DC. N.O.
50 psi / 345 kPa	P574968	B	DC 2-wire.
50 psi / 345 kPa	P574967	E	DC 2-wire.
50 psi / 345 kPa	P575549	F	DC 3-wire.
50 psi / 345 kPa	P174396	C	AC/DC 3-wire.